

Alera

A fixed-height bathing system with integrated seat transfer and leg-lift facility, suitable for a range of care settings.



Offering exceptional value without compromising performance, the Alera is a cost-effective and ultra-efficient bathing system perfectly suited to care home or assisted living environments.

The Alera comes with powered seat traverse and has an integral leg-lift system to assist with bathing transfers in and out of the bath. Its unique leg-lift facility provides full leg support throughout the transfer process and also eliminates the need for carers to lift a bather's legs up and over the side of the bath.

Compact enough to fit into the space of a traditional style bath, the Alera's remarkably long internal length and extra-wide seating area also ensure outstanding levels of comfort.



Key features:

- Powered seat traverse effortlessly with patented leg-lift facility effortlessly transfers bather in and out of the bath without carer intervention.
- Innovative keyhole design reduces water usage and helps cut energy costs
- The 1700mm full length bath boasts extra-long internal bathing length and wide seating area, ensuring optimum comfort for bathers
- The ultra-compact 1500mm bath is perfect for space restricted environments
- TMV3 controls maintain a safe, comfortable, pre-set water temperature, reducing any risk of scalding
- Ensuring CAT5 water protection for your facility the stylish Easyshower 5 solution comes as standard with the 1700 Alera bath, giving carers flexibility and bathers a relaxing experience
- Easy clean stainless steel bath seat frame and adjustable nursing arms for client comfort and safety
- Reliable, quiet electronics with integrated battery backup safety system in case of mains power failure
- Ergonomic and intuitive remote handset for easy and simple operation
- 165kg (25 stone), safe lifting weight accommodates the majority of bathers
- Left or right-hand configurations adapt to any bathroom layout
- Featuring integrated BioCote anti-microbial technology as standard
- A choice of full or hoist access panels to suit a variety of applications



Gainsborough Healthcare Group
Life enhancing bathing.

01527 40022

info@gainsboroughbaths.com

www.gainsboroughbaths.com

Alera

Key features and options



Lightweight, ergonomic hand operated shower unit option



Unique leg-lift facility support the bather into and out of the bath



TMV3 water temperature controls reduces risk of scalding



Folding nursing armrests for enhanced client safety



Lightweight, ergonomic handset with battery back-up system



Chromotherapy lighting



Hydrotherapy air-spa system

Key features and options:

- Easyshower5 - KIWA approved deck mounted CAT 5 shower system, including sequential thermostatic valve, trigger shower head, 1.5m hose, twin lever bath filler tap and TMV – 1700 baths
- KIWA compliant shower pole, (CAT 5) - Including shower head, diverter, twin lever bath filler tap and TMV3 valves – 1500 baths
- Auto-fill technology – temperature-controlled auto-fill system automatically fills the bath to a pre-set depth
- Hydrotherapy air-spa system – delivers a gentle, therapeutic massage to bathers
- Sound system – Bluetooth® compatible audio system for added bathing ambience and stimulation
- Chromotherapy system – multi-coloured LED lighting visually enhances the bathing experience



Gainsborough Healthcare Group
Life enhancing bathing.

01527 40022

info@gainsboroughbaths.com
www.gainsboroughbaths.com

Alera

Technical specification

Length (mm)	1500/1700
Width (mm)	750
Height (mm)	685
Internal depth (mm)	420
Footwell width (mm)	420
Internal width (mm)	605
Internal length (mm)	1275/1475
Seat Base length / width (mm)	460/430
Seat transfer height when down outside bath (mm).	535
Bath height with shower pole 1500 baths only (mm)	1586
Hoist Tunnel Panel where specified 1500/1700 (mm)	130*800 / 130*1000
Maximum user weight	165kg Fixed seat
Water capacity	1500mm - 200 litres 1700mm - 230 litres
Approximate bath weight (empty)	Alera 1500mm - 125kg Alera 1700mm - 130kg
Approximate bath weight (full)	Alera 1500mm - 325kg Alera 1700mm - 360kg
Typical mechanical operation times	Seat - Alera 266 secs/cycle

Class I Electrical Device	
Power supply	Mains 230V to be supplied via 30mA RCD
Operating voltage	24V
Battery backup	24V DC lead acid, for emergency use only
Actuator duty cycle	Max. 10% or 2min continuous use followed by 18min not in use. The life cycle test has been performed with a stabilised power supply (10% duty cycle) on a 20mm stroke actuator at max. load for 10,000 cycles at ambient temperature
Water supply	Unblended Hot & Cold water at 1bar Min > 3.5bar Max pressure
IP Rating	IPX3
A' weighted sound emission	<60dB(A)
A' weighted sound emission with air spa system (option)	<75dB(A)
Ambient temperature range	5°C to 50°C
Relative humidity range	10-80%
Atmospheric pressure range	50kPa to 106kPa
Medical Device Category	Class I

Antimicrobial protection

This bath includes BioCote® technology which has been proven to reduce bacteria and even some viruses, including influenza A H1N1, E.coli, MRSA and Pseudomonas.

Intended use

This equipment is intended to facilitate the bathing of residents in care facilities or in a home care environment. The product is designed to help people who struggle with getting in and out of a bath, especially those with physical limitations. It's useful for both hygiene and relaxation purposes.

Caution

To ensure best practice and safety the bath must be operated only by a trained professional with adequate understanding of the specific environment, its common practices and processes. It is vital that regular assessments of the bather are undertaken to ensure the bath remains suitable.

Please be aware of the sound emission and any optional accessories working attributes to ensure bather suitability before operation.

If you have any questions regarding this product or operation of the bath, feel free to contact your authorised representative or Gainsborough Healthcare Group Ltd. on 01527 400022.



Gainsborough Healthcare Group
Life enhancing bathing.

01527 400022

info@gainsboroughbaths.com
www.gainsboroughbaths.com

Alera

Technical Drawings

Alera

Dimensions in millimetres (mm).

Right-hand example (handing of a bath is indicated by the exit point of the bath when in a seated position).

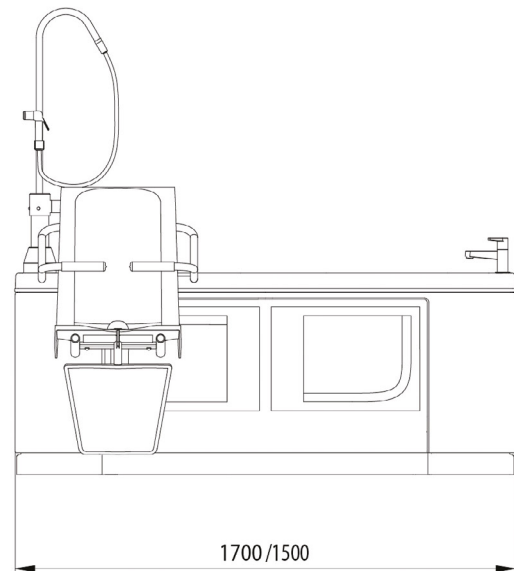
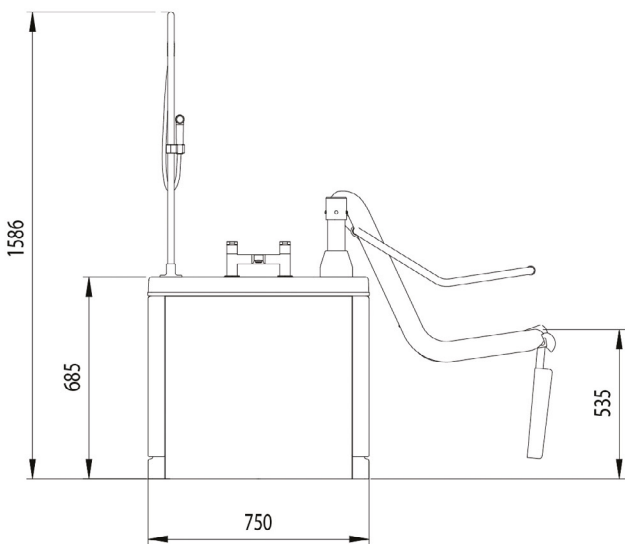
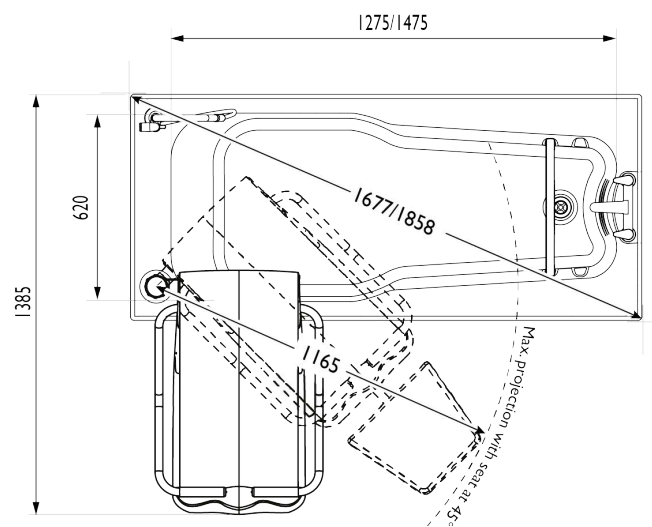
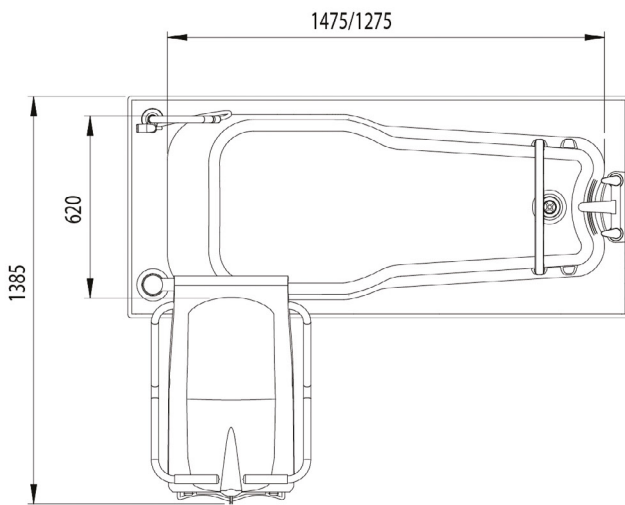

Fig 0025

